



Discover the ideal solution with **record**, your partner in door automation

**Drive technology for pedestrian entrances and industrial applications**

- > Automatic sliding doors, curved, straight, angular, reinforced, slim-line, with 1 or 2 leaves
- > Swinging
- > Folding
- > Telescopic
- > High speed gates
- > Range of sensors

**Security**

**Protection of People**

- > Fire-proof sliding doors
- > Smoke-resistant doors
- > Air tight doors
- > Doors for emergency exits

**Protection of buildings**

- > Burglar-resistant safety doors
- > Safety doors and interlocks for controlled passage
- > "one-way" corridors
- > Security doors

**Centralised monitoring**

- > Door management system for building access control
- > Alarm system and diagnostics
- > Interfaces

**Maintenance**

**Tailored advise**

- > Customised advice
- > Engineering professionalism
- > Maintenance of all automatic doors
- > Troubleshooting hot-line
- > Renovation
- > Remote control maintenance

**Special solutions**

- > Revolving doors

**● Headquarters**

> agta record ltd  
 Allmendstrasse 24  
 CH-8320 Fehraltorf  
**Tel. + 41 44 954 91 91**  
 Fax + 41 44 954 92 00  
 e-mail: info@agta-record.com

**● Production**

> agtatec ltd  
 Allmendstrasse 24  
 CH-8320 Fehraltorf  
 e-mail: agtatec@record.ch



Headquarters in Fehraltorf, Switzerland



www.agta-record.com



your global partner for entrance solutions

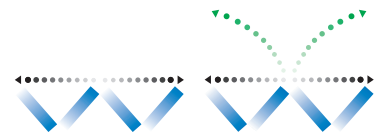

**Automatic folding door**  
**Automatic folding door** for use in escape and rescue routes

**record 16 FTA**  
**record 16 FBO**



**Real space savers!**



**record**

your global partner for entrance solutions



# record 16 FTA and 16 FBO automatic folding doors

## Elegant-silent-reliable

Where space is at a premium, record's folding doors allow quick and easy access. Ideally suited to buildings with narrow entrances, they are the perfect solution for restaurants, hotels, business premises, hospitals and homes for the elderly, as well as offices and private buildings. The folding doors use record's proven system 16 drive and control units, and have all the features and functions of **record's 16 STA** standard operator. The folding door can be face fixed or mounted in line.

# record 16 FBO folding door

## For safe and reliable opening in emergencies

The **16 FBO** folding door was specially developed for use in escape and rescue routes. In normal use, the door panels fold inwards. In emergencies, access to escape and rescue routes is provided by light pressure on the door panel. This frees the track from its mountings, allowing the door panel and track to open outwards.



### Technical Data

#### 16 FTA/16 FBO

<b>Clear opening width A</b>	800 - 2'000 mm
<b>Clear height of passage G</b>	2'500 mm
Recommended maximum height	2'500 mm
<b>Max. weight of door leaves</b>	4 x 37,5 kg, max. 150 kg
weight in total	4 x 37,5 kg, max. 150 kg
<b>Operator dimensions, incl. casing</b>	
height	180 mm
depth	240 mm
<b>Door movements (programmable)</b>	
Opening	max. 0.7m/1.0 s
Closing	max. 0.5m/1.0 s
<b>Electrical connection data</b>	
mains voltage	230 V, 50 / 60 Hz
rated power	0,6 A
rated capacity	100 W
rated capacity standby mode	14 W
fuse protection	min. 2.5 A slow

**Always safe**

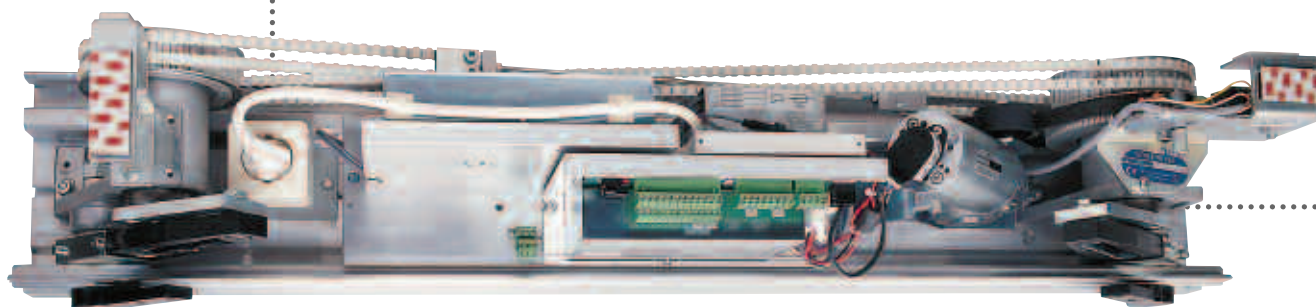

## Wall mounting

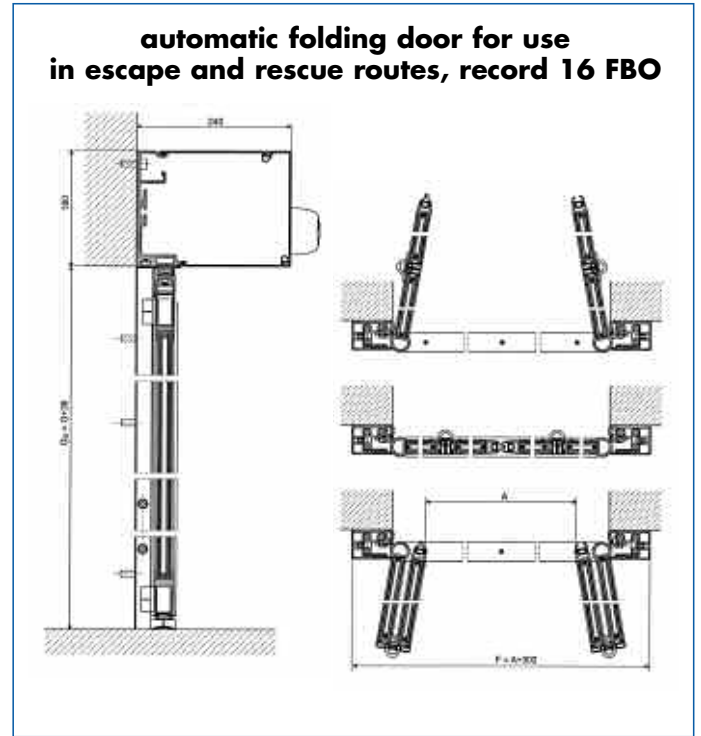
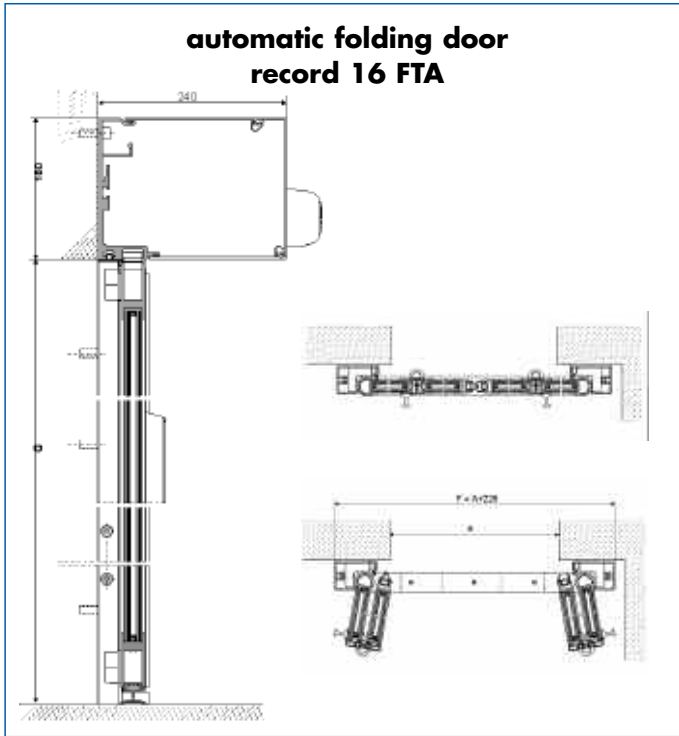

## Passage mounting

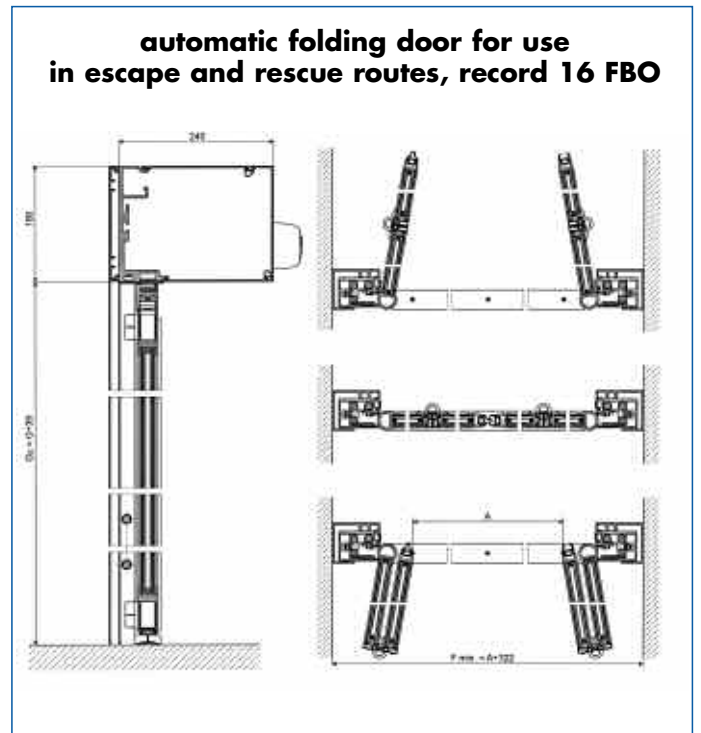
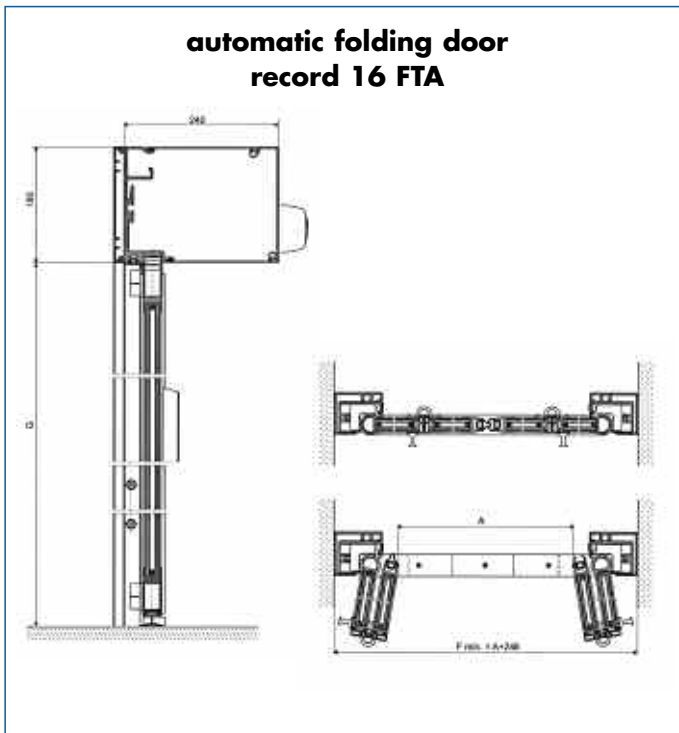

**A:** clear opening width **G:** height of passage **F:** length of operator header

**always reliable**

